

"WiFly GX" 802.11G Super Module

Features

- 802.11b/g PHY/MAC at up to 54Mbps
- Qualified 2.4GHz IEEE 802.11b/g transceiver
- Wi-Fi Alliance certified for WPA2-PSK
- Ultra-low power - 4uA sleep, 40mA Rx, 210mA Tx (max)
- Multiple sleep modes, wake up timer or signal
- Small form factor 28mm x 40.8mm
- UART, RS-232, RS-485 or SPI hardware interfaces
- On board ceramic chip antenna and U.FL connector for external antenna
- 15 PIOs and 8 sensor pins for general use
- Real-time clock for wakeup and time stamps
- Accepts wide voltage range input 3.3V – 12VDC (RN-121 and RN-122)
- Industrial voltage range input 6V – 48VDC (RN-123 and RN-125)
- Switched power supply for external sensors
- Supports Adhoc and infrastructure networking
- FCC / CE / ICS certified and RoHS compliant.
- High speed UART up to 2Mbit/s (RN-122)
- High speed UART 64 bytes FIFO (RN-122)
- Onboard 14 bit temperature sensor (RN-121-TEMP)
- Onboard 12 bit humidity sensor (RN-121-TEMP)

Applications

- Wireless thermostats
- RS232/RS485 cable replacement
- Remote equipment monitoring
- Scanners, GPS and measurement systems
- Industrial sensor and control
- Security
- Home Automation
- Medical devices

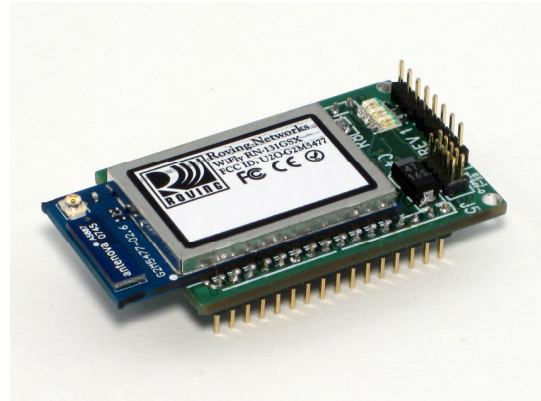

Description

The WiFly GX module is a stand alone, embedded wireless LAN/WAN access device. Because of its small form factor and extremely low power consumption, the RN-121G is perfect for mobile wireless applications such as asset monitoring, GPS tracking and portable devices. The WiFly GX simplifies the integration and development of your application by including an on board TCP/IP stack and networking application programs such as telnet and ftp. The hardware requires only four connections (PWR, TX, RX, GND) to create a simple wireless data connection. Additionally, continuously sampled analog inputs transmit audio, temperature, motion, or acceleration data without requiring additional hardware in your end application. The WiFly GX module uses a straight forward ASCII command set for configuration and programming. Once the WiFly GX is set up it can automatically associate and authenticate with a network, making your device accessible worldwide. The WiFly GX includes a high-speed UART and SPI interfaces that allow high-speed data transfer. The WiFly GX module is a complete wireless solution

Block Diagram

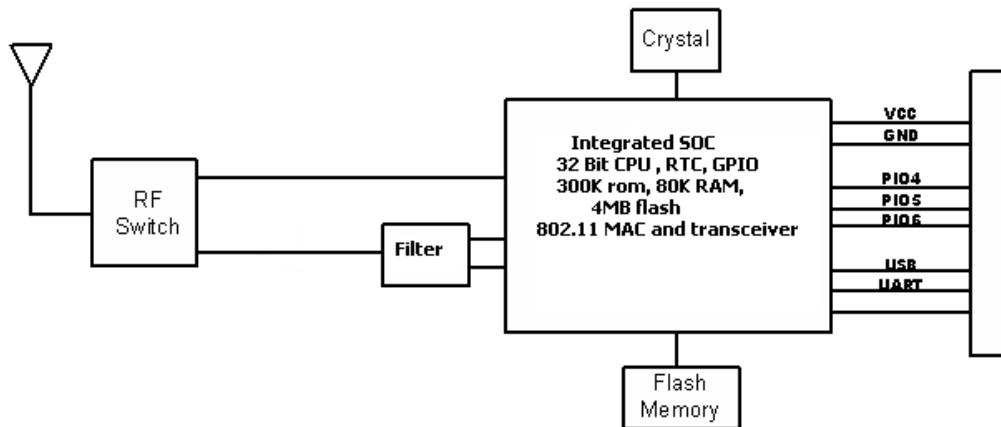

Overview

- Host Data Rate Up to 100 Mbps for SDIO, 44 Mbps for SPI and 2.7 Mbps for UART
- Throughput up to 4 Mbps with SPI, 2Mbps with the high speed UART
- Low power - 110mA TX, 35mA idle, 4uA deep sleep
- Real time clock for time stamping, auto-sleep and auto-wakeup modes
- UART and wireless configuration using simple ASCII commands.
- Over the air firmware upgrade (FTP)
- Three on board LEDs for status.
- 32 pin Standard 2mm DIP socket pin spacing
- 802.11i: Open, WEP-40, WEP-128, WPA-PSK (TKIP), WPA2-PSK, EAP-TLS for WPA1 & WPA2 Enterprise
- TCP/IP, DHCP, UDP, DNS, ARP, ICMP, FTP
- Supports 802.11 power save modes
- Commands for scanning networks roaming modes

High-speed UART features

- 64 bytes FIFO (transmitter and receiver)
- Fully compatible with industrial standard 16C450 and equivalent
- Baud rates up to 5 Mbit/s in 16^κ clock mode
- Auto hardware flow control using RTS/CTS
- Auto software flow control with programmable Xon/Xoff characters

SPI interface features

- SPI Master mode
- Data rate up to 22MHz
- Selectable clock phase and polarity
- Selectable data polarity

RS-485 features (RN-125 only)

- Accepts 6Vdc to 48Vdc power
- RS-485 signaling with auto-direction control
- Onboard line termination resistors

- Hot-Swappable for Telecom Applications
- 1/4-Unit Load, Allowing Up to 128 Transceivers on the Bus

Environmental Conditions

Parameter	Value
Temperature Range (Operating)	-30 °C ~ +85 °C
Temperature Range (Storage)	-40 °C ~ +85 °C
Relative Humidity (Operating)	≤90%
Relative Humidity (Storage)	≤90%

Radio Characteristics

Parameter	Specifications
Frequency	2402 ~ 2480MHz
Modulation	802.11b compatibility : DSSS(CCK-11, CCK-5.5, DQPSK-2, DBPSK-1) 802.11g : OFDM (default)
Channel intervals	5MHz
Channels	1 - 14
Transmission rate (over the air)	1 – 11Mbps for 802.11b / 6 – 54Mbps for 802.11g
Receive sensitivity	-85dBm typ.
Output level (Class1)	+18dBm
Maximum RF input to U.FL connector	10 dBm

Pin Description: RN-121 (SPI interface)

Note: Any unused pins should be left floating (No Connect)

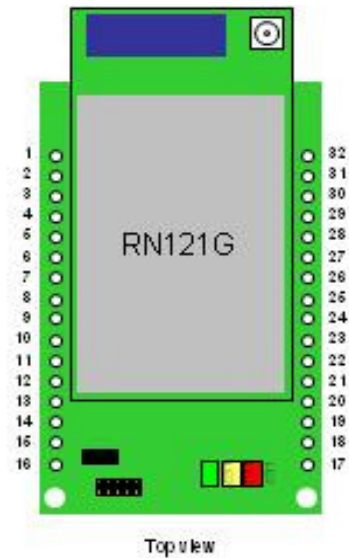

Pin	Name	Description	Default
1	PIO7	General Purpose IO	No Connect
2	SPOWER	Switched sensor output power	No Connect
3	SENSE-4	Analog sensor input (1.2V)	
4	SENSE-5	Analog sensor input (1.2V)	
5	SENSE-6	Analog Sensor Input (1.2V)	
6	SENSE-7	Analog Sensor Input (1.2V)	
7	PIO6	Controls red LED	Input
8	PIO9	General purpose IO	Sets factory defaults
9	DEBUG_RX	2 nd serial port	No Connect
10	DEBUG_TX	2 nd serial port	No Connect
11	RESET	Active low with 10k built in pullup	
12	WAKE	Force the module to wake up, input to module, 31us min. pulse	No Connect
13	VIN	3.6-16VDC	
14	VREG	3.3V LDO output	
15	VBATT	Tie to VREG if USING VIN	Battery option
16	GND	Ground	
17	VDD	3.3V out-in	Power input
18	SPI_MOSI	Spi port MOSI line (WiFly GX is the master)	Output
19	SPI_CK	Spi port clock line (WiFly GX is the master)	Output
20	SPI_CS	Spi port chip-select line (WiFly GX is the master)	Output
21	SPI_MISO	Spi port MISO line (WiFly GX is the master)	Input
22	PIO5	Controls yellow LED	Connect/disconnect input
23	PIO4	Controls green LED	Connection status output
24	RTSB/PIO13	HW flow control output (Onboard UART) / General purpose IO	TTL output
25	CTSB/PIO12/ SENSE-1	HW flow control input (Onboard UART) / General purpose IO / Analog sensor input (3.3V)	TTL input
26	RXB / SENSE-0	TTL Data IN (Onboard UART) / Analog sensor input (3.3V)	Input
27	TXB	TTL Data Out (Onboard UART)	Output
28	NC		No Connect
29	SENSE-3	Analog sensor input (3.3V)	No Connect
30	SENSE-2	Analog sensor input (3.3V)	No Connect
31	NC		No Connect
32	GND	Ground	

Pin Description: RN-122 (Dual UART)

Note: Any unused pins should be left floating (No Connect)

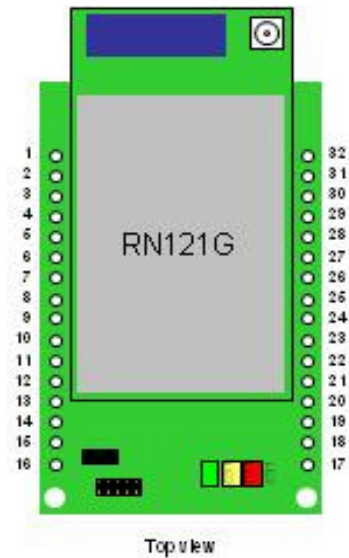

Pin	Name	Description	Default
1	PIO7	General Purpose IO	No Connect
2	SPOWER	Switched sensor output power	No Connect
3	SENSE-4	Analog sensor input (1.2V)	
4	SENSE-5	Analog sensor input (1.2V)	
5	SENSE-6	Analog Sensor Input (1.2V)	
6	SENSE-7	Analog Sensor Input (1.2V)	
7	PIO6	Controls red LED	Input
8	PIO9	General purpose IO	Sets factory defaults
9	DEBUG_RX	2 nd serial port	No Connect
10	DEBUG_TX	2 nd serial port	No Connect
11	RESET	Active low with 10k built in pullup	
12	WAKE	Force the module to wake up, input to module, 31us min. pulse	No Connect
13	VIN	3.6-16VDC	
14	VREG	3.3V LDO output	
15	VBATT	Tie to VREG if USING VIN	Battery option
16	GND	Ground	
17	VDD	3.3V out-in	Power input
18	UART_Clock	High speed UART clock input	No Connect
19	NC		No Connect
20	PIO8	General purpose IO	No Connect
21	NC		No Connect
22	PIO5	Controls yellow LED	Connect/disconnect input
23	PIO4	Controls green LED	Connection status output
24	RTSB/PIO13	HW flow control output (Onboard UART) / General purpose IO	TTL output
25	CTSB/PIO12/ SENSE-1	HW flow control input (Onboard UART) / General purpose IO / Analog sensor input (3.3V)	TTL input
26	RXB / SENSE-0	TTL Data IN (Onboard UART) / Analog sensor input (3.3V)	Input
27	TXB	TTL Data Out (Onboard UART)	Output
28	RTSA	TTL HW flow control output (External UART)	Output
29	CTSA / SENSE-3	TTL HW flow control input (External UART) / Analog sensor input (3.3V)	Input
30	RXA/SENSE- 2	TTL Data IN (External UART) / Analog sensor input (3.3V)	Input
31	TXA	TTL Data Out (External UART)	Output
32	GND	Ground	

GPIO/Modem header

Pin	Name	Description	Default
1	GPIO0	General Purpose IO	No Connect
2	GPIO1	General Purpose IO	No Connect
3	GPIO2	General Purpose IO	No Connect
4	GPIO3	General Purpose IO	No Connect
5	GPIO4/DSRA	General Purpose IO/DSR (External UART)	No Connect
6	GPIO5/DTRA	General Purpose IO/DTR (External UART)	No Connect
7	GPIO6/CD	General Purpose IO/CD (External UART)	No Connect
8	GPIO7/RI	General Purpose IO/RI (External UART)	No Connect

Electrical Characteristics: RN-121 (SPI interface) / RN-122 (Dual UART)

Parameter	Min	Typ.	Max.	Unit
Supply Voltage VIN (RN-122 only)	4.0	5.0	12	VDC
Supply Voltage VDD	3.0	3.3	3.6	VDC
Supply Voltage (VBATT option)	2.0	3.0	3.3	VDC
UART_Clock HIGH-level input voltage (RN-122 only)	2.4	-	5.5	VDC
UART_Clock LOW-level input voltage (RN-122 only)				
UART_Clock input capacitance	-	-	3	pF
Average power consumption				
Standby/Idle (default settings)	-	35	-	mA
Sleep	10	12	15	uA (micro)
Connected(idle, RX)		40		mA
Connected(TX)		110	180	mA

** Note: The RN-122 does not have a regulator fitted and should not be powered from VIN.

The power management unit turns off unused functions and switches between sleep and active modes. In sleep mode the real-time clock and sensor interface remain active, enabling the WiFly to wake up at any interval or when a specific condition is detected. This “instant-on” capability allows mobile devices to remain in low-power sleep mode until it is ready to transfer data. **The WiFly module can wake up, join a network, transmit data and go back to sleep in under 100 msec.**

This unique combination of low latency and low power makes it possible to run for over two years transmitting data every 5 minutes using just two standard AAA Alkaline batteries!

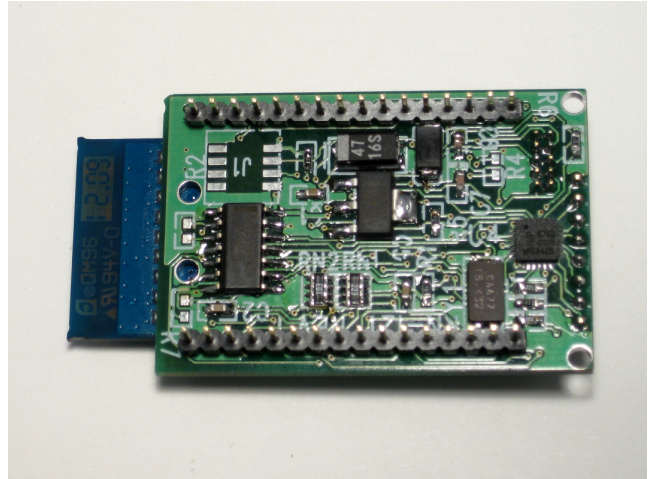

RN-121/ 122 Module Dimensions

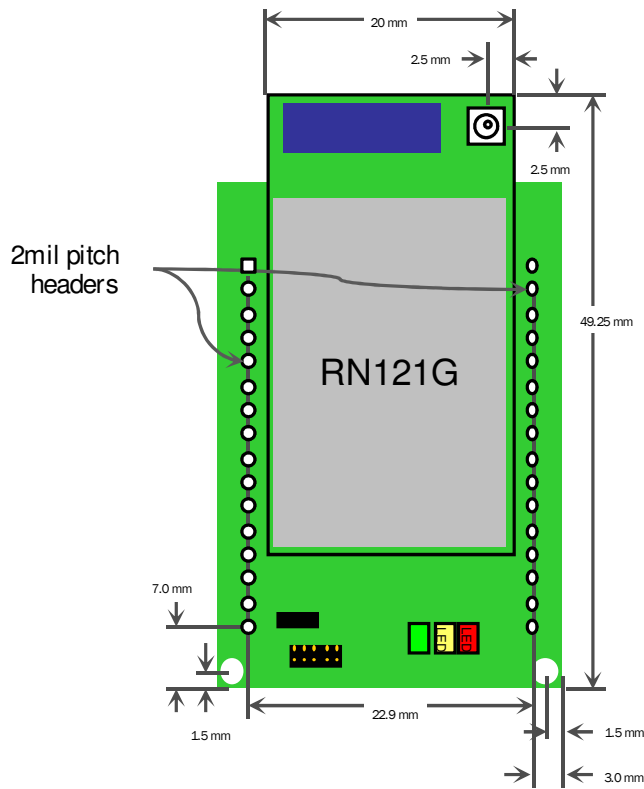

Pin Description: RN-123 (RS-232 interface)

Note: Any unused pins should be left floating (No Connect)

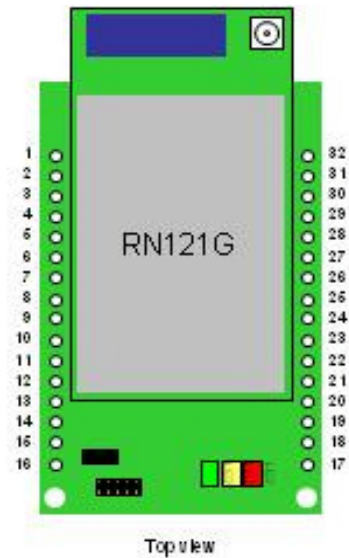

Pin	Name	Description	Default
1	PIO7	General Purpose IO	No Connect
2	SPOWER	Switched sensor output power	No Connect
3	SENSE-4	Analog sensor input (1.2V)	
4	SENSE-5	Analog sensor input (1.2V)	
5	SENSE-6	Analog Sensor Input (1.2V)	
6	SENSE-7	Analog Sensor Input (1.2V)	
7	PIO6	Controls red LED	Input
8	PIO9	General purpose IO	Sets factory defaults
9	DEBUG_RX	2 nd serial port	No Connect
10	DEBUG_TX	2 nd serial port	No Connect
11	RESET	Active low with 10k built in pullup	
12	WAKE	Force the module to wake up, input to module, 31us min. pulse	No Connect
13	VIN	6-48VDC	
14	P5V	5VDC input option	No Connect
15	NC		No Connect
16	GND	Ground	
17	P3.3V	3.3V out-in	No Connect
18	ENA_3.3V	Enable 3.3V regulator (pull low to disable)	No Connect
19	TXB-	RS485 line	
20	TXA+	RS485 line	
21	PIO8	General purpose IO	No Connect
22	PIO5	Controls yellow LED	Connect/disconnect input
23	PIO4	Controls green LED	Connection status output
24	RTSB	TTL HW flow control output	No Connect
25	CTSB	TTL HW flow control input	No Connect
26	RXDB	TTL Data IN	No Connect
27	TXDB	TTL Data Out	No Connect
28	RXDA	RS232 Data IN	RS232 input
29	TXDA	RS232 Data Out	RS232 output
30	RTSA	RS232 HW flow control output	RS232 output
31	CTSA	RS232 HW flow control input	RS232 input
32	GND	Ground	

Electrical Characteristics: RN-123 (RS-232 interface)

Parameter	Min	Typ.	Max.	Unit
Supply Voltage VIN	6.0	24	48	VDC
Supply Voltage P5V	4.0	5.0	6.0	VDC
Supply Voltage P3.3V	3.0	3.3	3.6	VDC
Average power consumption				
Standby/Idle (default settings)	-	35	-	mA
Sleep	10	12	15	uA (micro)
Connected(idle, RX)		40		mA
Connected(TX)		110	180	mA

Pin Description: RN-125 (RS-485 interface)

Note: Any unused pins should be left floating (No Connect)

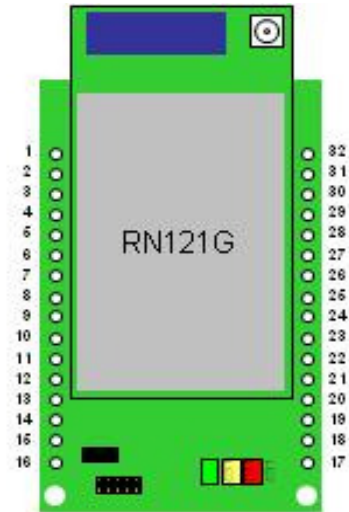

Top view

Pin	Name	Description	Default
1	PIO7	General Purpose IO	No Connect
2	SPOWER	Switched sensor output power	No Connect
3	SENSE-4	Analog sensor input (1.2V)	
4	SENSE-5	Analog sensor input (1.2V)	
5	SENSE-6	Analog Sensor Input (1.2V)	
6	SENSE-7	Analog Sensor Input (1.2V)	
7	PIO6	Controls red LED	
8	PIO9	General purpose IO	Sets factory defaults
9	DEBUG_RX	2 nd serial port	No Connect
10	DEBUG_TX	2 nd serial port	No Connect
11	RESET	Active low with 10k built in pullup	
12	WAKE	Force the module to wake up, input to module, 31us min. pulse	No Connect
13	VIN	6-48VDC	
14	P5V	5VDC input option	No Connect
15	T2	RS485 Terminator – Tie to P5V to terminate	No Connect
16	GND	Ground	
17	P3.3V	3.3V out-in	No Connect
18	ENA_3.3V	Enable 3.3V regulator (pull low to disable)	No Connect
19	TXB-	RS485 line	RS485
20	TXA+	RS485 line	RS485
21	PIO8	General purpose IO	No Connect
22	PIO5	Controls yellow LED	Connect/disconnect input
23	PIO4	Controls green LED	Connection status output
24	NC		No Connect
25	NC		No Connect
26	NC		No Connect
27	NC		No Connect
28	NC		No Connect
29	NC		No Connect
30	NC		No Connect
31	T1	RS485 Terminator – Tie to GND to terminate	No Connect
32	GND	Ground	

Electrical Characteristics: RN-125 (RS485 interface)

Parameter	Min	Typ.	Max.	Unit
Supply Voltage VIN	6.0	24	48	VDC
Supply Voltage P5V	4.0	5.0	6.0	VDC
Average power consumption				
Standby/Idle (default settings)	-	35	-	mA
Sleep	10	12	15	uA (micro)
Connected(idle, RX)		40		mA
Connected(TX)		110	180	mA

**Note: The 3.3V Power input should not be used to power the RN-125 since the RS-485 driver requires a higher input voltage.

Design Concerns

1. **Reset circuit.** Reset is active LOW, is optional and does not need to be connected. There is a built in voltage monitor that will pull Reset LOW (open drain FET) if the input voltage drops below 2.7VDC. If external reset is desired, use an OPEN DRAIN driver and do not drive the Reset pin to any voltage > 1.0 Vdc.
2. **Powering the WiFly Module.** There are 3 options to power the RN-121.
 - Supply 3.6 to 16VDC power to VIN (pin 13). Tie VREG (pin 14) to VBATT (pin 15).
 - Apply 3.3VDC regulated power to VDD (pin 17).
 - Apply battery = 2.0 to 3.0VDC to VBATT (pin 15).If VIN is powered, VREG will supply 3.3VDC output and can be used for other circuits, with a current limitation of 50 ma.

Warning: Placing 5VDC or any voltage above 3.3Vdc into the VDD pins of the module will permanently damage the radio module. Be sure to use the VIN = pin 13 power pin for any power supplied that is > 3.3VDC.
3. **Factory reset PIO9 (pin 8).** It is a good idea to connect this pin to a switch, or jumper, or resistor, so it can be accessed. This pin can be used to reset the module to FACTORY DEFAULTS and is often critical in situations where the module has been mis-configured.
4. **GPIO connections:** Placing 3.3Vdc into the PIO's while they are set as outputs will permanently damage the radio modules. The failure mode is a short across GND and VCC. Use a 10KΩ resistor in series or a 10KΩ pull up resistor for input and output PIO's respectively.
5. **Sensor connections.** The Sensor inputs SENS1-8 are extremely sensitive to over voltage. Under no conditions should these pins be pulled high above 1.2VDC. Placing any voltage above this will permanently damage the radio module.
6. **Connection status.** PIO5 is available to drive an LED, and blinks at various speeds to indicate status. PIO2 is an output which directly reflects the connection state, it goes HIGH when connected, and LOW otherwise.
7. **Minimizing Radio interference.** When integrating the WiFly module with on board chip antenna be sure the area around the chip antenna end the module protrudes at least 5mm from the PCB and any metal enclosure. If this is not possible use the external antenna option with the U.FL to reverse polarity SMA connector.
8. **Connecting to the GPIO.** Placing 3.3Vdc into the PIO's while they are set as outputs will permanently damage the radio. The failure mode is short across GND and VCC. Use a 10KΩ resistor in series or a 10KΩ pull up resistor for input and output PIO's respectively.
 - Make sure to connect a common ground when using the external TX, RX inputs on the 0 – 3.3Vdc
 - For a 3 wire DB-9 interface (tx, rx, gnd only) connect/short CTS to RTS, Factory default is hardware flow control enabled CTS and RTS connected.
 - When using a 5.0Vdc Input, PIO's require a 10K ohm series resistor. PIO's are 0-3.3Vdc not 5 volt tolerant.

Compliance Information

- FCC Certified
- Environmentally friendly RoHS compliant

Ordering Information

Part Number	Description
RN-121	UART and SPI interfaces, pin compatible with RN-111B
RN-121-TEMP	With onboard temperature and humidity sensors
RN-122	With two UARTS, one high-speed, pin compatible with RN-111B
RN-123	With RS-232 interface
RN-125	With RS-485 interface
For other configurations, contact Roving Networks directly.	

Visit <http://www.rovingnetworks.com> for current pricing and a list of distributors carrying our products.

Copyright © 2009 Roving Networks. All rights reserved.

Roving Networks reserves the right to make corrections, modifications, and other changes to its products, documentation and services at any time. Customers should obtain the latest relevant information before placing orders and should verify that such information is current and complete.

Roving Networks assumes no liability for applications assistance or customer product design. Customers are responsible for their products and applications using Roving Networks components. To minimize the risks associated with customer products and applications, customers should provide adequate design and operating safeguards.

Roving Networks products are not authorized for use in safety-critical applications (such as life support) where a failure of the Roving Networks product would reasonably be expected to cause severe personal injury or death, unless officers of the parties have executed an agreement specifically governing such use.

All other trademarks are property of their respective owners.