

## Class 1 Bluetooth® Module



### Features

- Fully qualified Bluetooth 2.1/2.0/1.2/1.1 module
- Bluetooth v2.0+EDR support
- Postage stamp sized form factor, 13.4mm x 25.8 mm x2mm
- Low power (30mA connected,, <10mA sniff mode)
- UART (SPP or HCI) and USB (HCI only) data connection interfaces.
- Sustained SPP data rates - 240Kbps (slave), 300Kbps (master)
- HCI data rates - 1.5Mbps sustained, 3.0Mbps burst in HCI mode
- 8MB on board flash, HCI mode, or SPP/DUN software stacks available.
- Embedded Bluetooth stack profiles included (requires no host stack): GAP, SDP, RFCOMM and L2CAP protocols, with SPP and DUN profile support.
- Bluetooth SIG Qualified, End Product Listing
- Castellated SMT pads for easy and reliable PCB mounting
- Class 1 high power amplifier with on board ceramic RF chip antenna.
  - Certifications: FCC, ICS, CE
  - Environmentally friendly, RoHS compliant

### Applications

- Cable replacement
- Barcode scanners
- Measurement and monitoring systems
- Industrial sensors and controls
- Medical devices
- Asset tacking

### Description

The RN41 is a small form factor, low power, highly economic Bluetooth radio for OEM's adding wireless capability to their products. The RN41 supports multiple interface protocols, is simple to design in and fully certified, making it a complete embedded Bluetooth solution. With its high performance on chip antenna and support for Bluetooth® Enhanced Data Rate (EDR), the RN41 delivers up to 3 Mbps data rate for distances to 100M. Designers can easily customize their application using up to 8Mbits of flash memory. The RN41 is the perfect product for engineers wanting to add wireless capability to their product but don't want to spend significant time and money developing Bluetooth specific hardware and software.

### Block Diagram

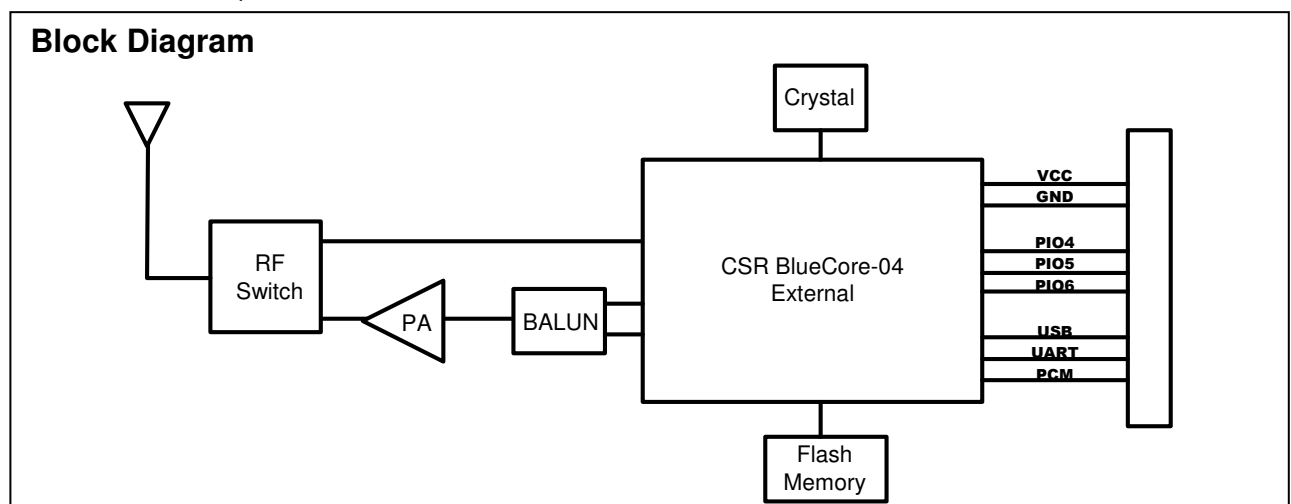

## Overview

- Baud rate speeds: 1200bps up to 921Kbps, non-standard baud rates can be programmed.
- Class 1 radio, 330' (100m) distance, 12dBm output transmitter, -80dBm typical receive sensitivity
- Frequency 2402 ~ 2480MHz,
- FHSS/GFSK modulation, 79 channels at 1MHz intervals
- Secure communications, 128 bit encryption
- Error correction for guaranteed packet delivery
- UART local and over-the-air RF configuration
- Auto-discovery/pairing requires no software configuration (instant cable replacement).
- Auto-connect master, IO pin (DTR) and character based trigger modes

## Environmental Conditions

Parameter	Value
Temperature Range (Operating)	-40 °C ~ 85 °C
Temperature Range (Storage)	-40 °C ~ 85 °C
Relative Humidity (Operating)	≤90%
Relative Humidity (Storage)	≤90%

## Electrical Characteristics

Parameter	Min	Typ.	Max.	Unit
Supply Voltage (DC)	3.0	3.3	3.6	V
RX Supply Current		35	60	mA
TX Supply Current		65	100	mA
<b>Average power consumption</b>				
Standby/Idle (default settings)		25		mA
Connected (normal mode)		30		mA
Connected (low power Sniff)		8		mA
Standby/Idle (Deep sleep enabled)	250uA	2.5		mA

## Radio Characteristics

Parameter	Freq. (GHz)	Min	Typ	Max	Bluetooth Specification	Units
Sensitivity @ 0.1%BER	2.402	-	-80	-86	≤ -70	dBm
	2.441	-	-80	-86		dBm
	2.480	-	-80	-86		dBm
RF Transmit Power	2.402	15.0	16.0		≤ 15	dBm
	2.441	15.0	16.0			dBm
	2.480	15.0	16.0			dBm
Initial Carrier Frequency Tolerance	2.402	-	5	75	75	kHz
	2.441	-	5	75		kHz
	2.480	-	5	75		kHz
20dB bandwidth for modulated carrier		-	900	1000	≤ 1000	kHz
Drift (Five slots packet)		-	15	-	40	kHz
Drift Rate		-	13	-	20	kHz
Δf <sub>1avg</sub> Max Modulation	2.402	140	165	175	>140	kHz
	2.441	140	165	175		kHz
	2.480	140	165	175		kHz
Δf <sub>2avg</sub> Min Modulation	2.402	140	190	-	115	kHz
	2.441	140	190	-		kHz
	2.480	140	190	-		kHz

## Pin Description

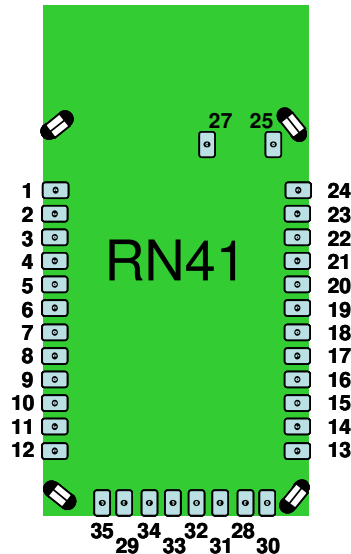

Top view

Pin	Name	Description	Default
1	GND		
2	SPI MOSI	Programming only	No Connect
3	PIO6	Set BT master (HIGH=auto-master mode)	Input to RN41 with weak pulldown
4	PIO7	Set Baud rate (HIGH = force 9600, LOW = 115K or firmware setting)	Input to RN41 with weak pulldown
5	RESET	Active LOW reset	Input to RN41 with 1K pullup
6	SPI_CLK	Programming only	No Connect
7	PCM_CLK	PCM interface	No Connect
8	PCM_SYNC	PCM interface	No Connect
9	PCM_IN	PCM interface	No Connect
10	PCM_OUT	PCM interface	No Connect
11	VDD	3.3V regulated power input	
12	GND		
13	UART_RX	UART receive Input	Input to RN41
14	UART_TX	UART transmit output	High level output from RN41
15	UART_RTS	UART RTS, goes HIGH to disable host transmitter	Low level output from RN41
16	UART_CTS	UART CTS, if set HIGH, disables transmitter	Low level input to RN41
17	USB_D+	USB port	Pull up 1.5K when active
18	USB_D-	USB port	
19	PIO2	Status, HIGH when connected, LOW otherwise	Output from RN41
20	PIO3	Auto discovery = HIGH	Input to RN41 with weak pulldown
21	PIO5	Status, toggles based on state, LOW on connect	Output from RN41
22	PIO4	Set factory defaults	Input to RN41 with weak pulldown
23	SPI_CSB	Programming only	No Connect
24	SPI_MISO	Programming only	No Connect
25	GND		
26	NC	RF pad keep all traces and planes clear.	
27-29	GND		
30	AIO0	Optional analog input (Charge monitor)	Not Used
31	PIO8	Status (RF data rx/tx)	Output from RN41
32	PIO9	IO	Input to RN41 with weak pulldown
33	PIO10	IO (remote DTR signal)	Input to RN41 with weak pulldown
34	PIO11	IO (remote RTS signal)	Input to RN41 with weak pulldown
35	AIO1	Optional analog input (Battery monitor)	Not Used

## Digital I/O Characteristics

$2.7V \leq VDD \leq 3.0V$	Min	Typ.	Max.	Unit
Input logic level LOW	-0.4	-	+0.8	V
Input logic level HIGH	0.7VDD	-	VDD+0.4	V
Output logic level LOW	-	-	0.2	V
Output logic level HIGH	VDD-0.2	-	-	V
All I/O's (except reset) default to weakpull down	+0.2	+1.0	+5.0	$\mu A$

## Typical Application Circuit

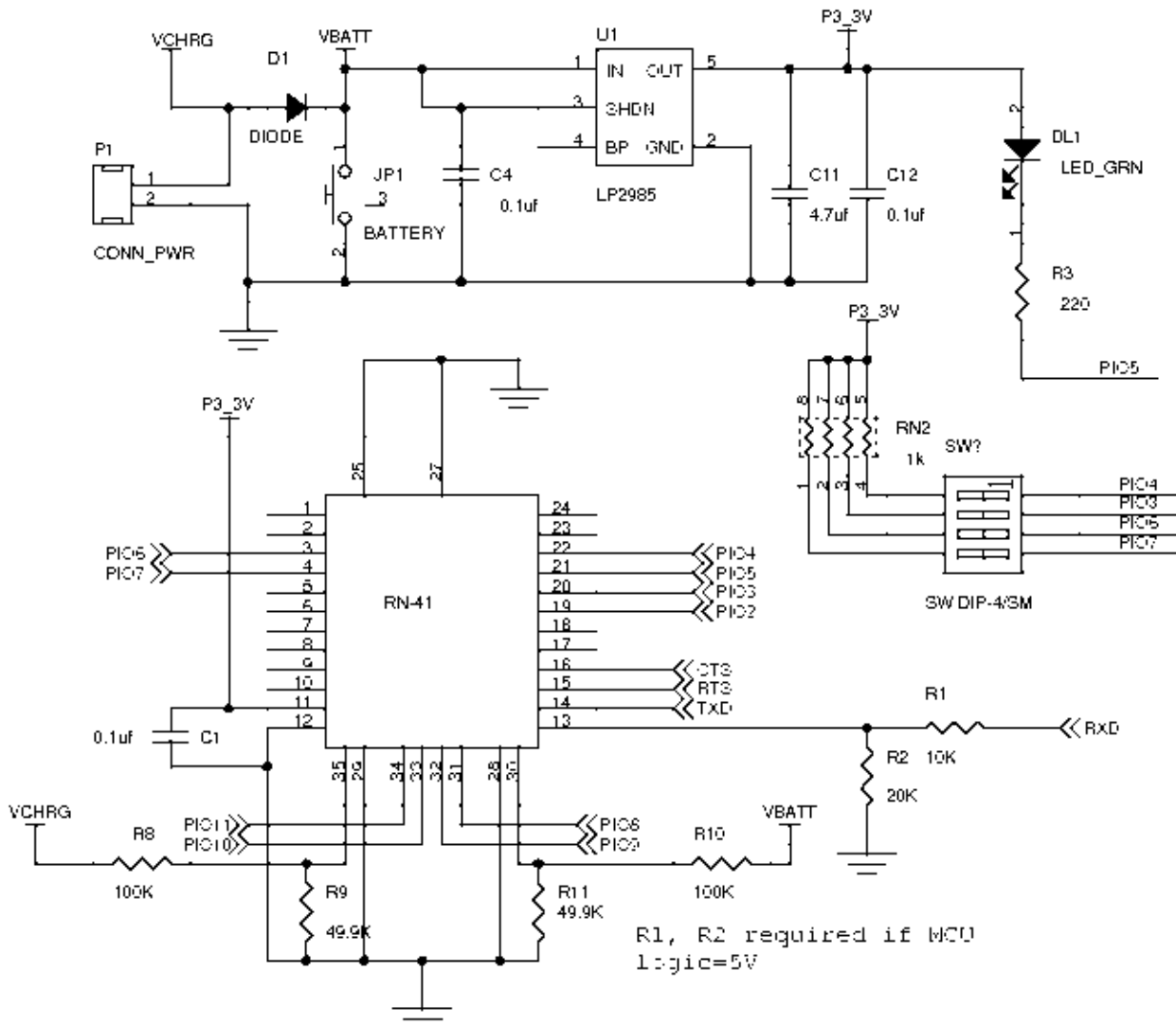

## Module Dimensions

PCB LAYOUT  
PAD SIZE = 0.8 X 1.30 mm

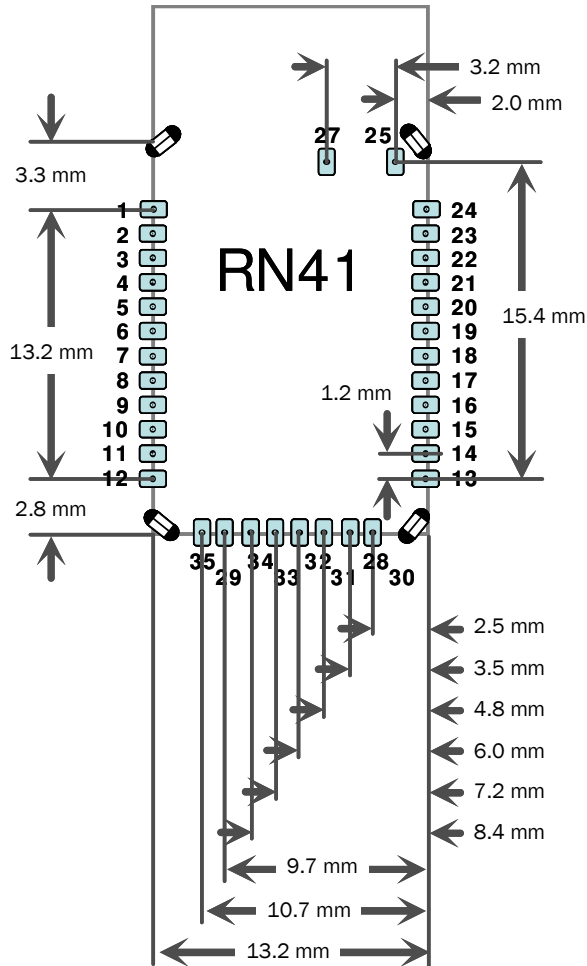

MODULE DIMENSIONS

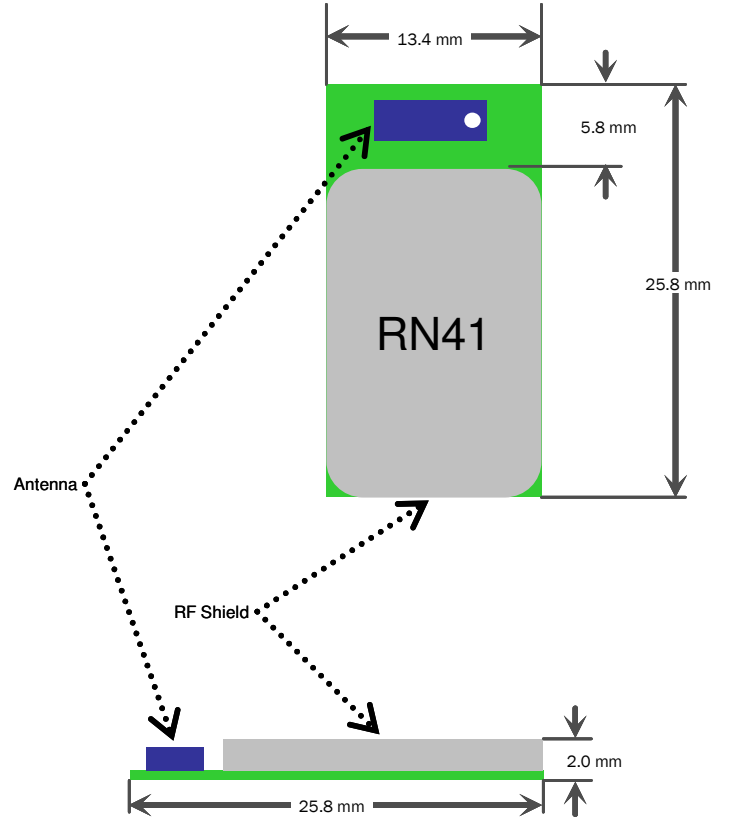

## Design Concerns

- Reset circuit.** RN-41 contains a 1k pullup to VCC, the polarity of reset on the RN41 is ACTIVE LOW. A power on reset circuit with delay is OPTIONAL on the reset pin of the module. It should only be required if the input power supply has a very slow ramp, or tends to bounce or have instability on power up. Often a microcontroller or embedded CPU IO is available to generate reset once power is stable. If not, there are many low cost power supervisor chips available, such as MCP809, MCP102/121, and Torex XC61F.
- Factory reset PIO4.** It is a good idea to connect this pin to a switch, or jumper, or resistor, so it can be accessed. This pin can be used to reset the module to FACTORY DEFAULTS and is often critical in situations where the module has been mis-configured. To set Factory defaults start HIGH, then toggle times.
- Connection status.** PIO5 is available to drive an LED, and blinks at various speeds to indicate status. PIO2 is an output which directly reflects the connection state, it goes HIGH when connected, and LOW otherwise.
- HCI mode.** The RN41 module must be loaded with special firmware to run in HCI mode. When in HCI mode the standard SPP/DUN applications are disabled.
- Using SPI bus for flash upgrade.** While not required, this bus is very useful for configuring advanced parameters of the Bluetooth modules, and is required for upgrading the firmware on modules. The suggested ref-design shows a 6pin header which can be implemented to gain access to this bus. A minimum-mode version could just use the SPI signals (4pins) and pickup ground and VCC from elsewhere on the design.

### 6. Minimizing Radio interference.

When laying out the carrier board for the RN41 module the areas under the antenna and shielding connections should not have surface traces, GND planes, or exposed vias. (See diagram to right) For optimal radio performance the antenna end of RN41 module should protrude 5mm past any metal enclosure.

### 7. Soldering Reflow Profile.

- Lead-Free Solder Reflow
- Temp: 230 degree C , 30-40 seconds, Peak 250 degree C maximum.
- Preheat temp: 165 +- 15 degree C, 90 to 120 seconds.
- Time: Single Pass, One Time

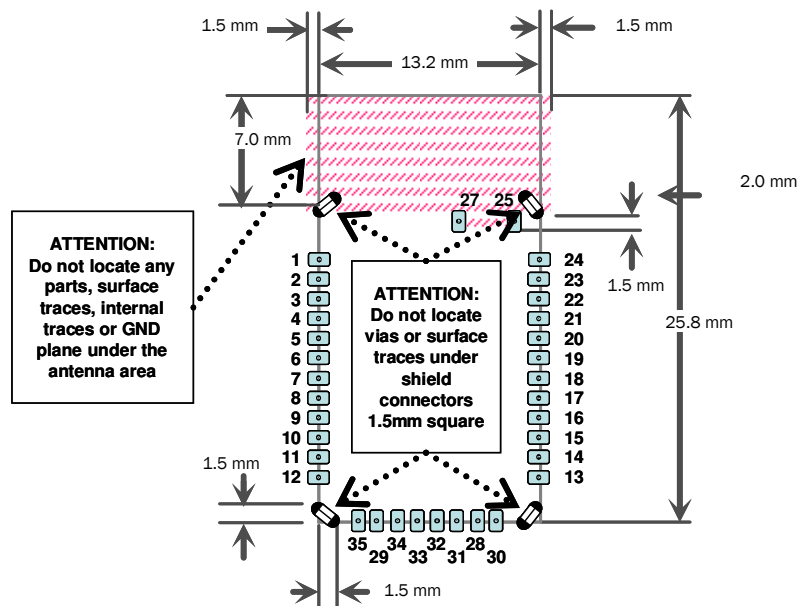

## Compliance Information

Category	Country	Standard
<b>Radio</b>	<b>USA</b>	FCC CFR47 Part 15 C, para 15.247
	<b>FCC ID:</b>	T9J-R41-1
	<b>EUROPE</b>	EN 300 328-1
		EN 300 328-2 2.4GHz
	<b>CANADA</b>	IC RSS-210 low power comm. device
	<b>IC Canada ID:</b>	6514A-RN411
<b>EMC</b>	<b>USA</b>	FCC CFR47 Part 15 subclass B
	<b>EUROPE</b>	EN 55022 Class B radiated
		EN61000-4-2 ESD immunity
		EN61000-4-3 radiated field
		EN61000-4-6 RF immunity
		EN61000-4-8 power magnetic immunity
<b>Bluetooth</b>	<b>LISTED</b>	B013180
<b>Environmental</b>	<b>RoHS</b>	RoHS compliant

## Ordering Information

Part Number	Description
RN-41	Standard Application firmware (SPP/DUN Master and Slave)
RN-41-H	HCI firmware (HCI over H4 UART)
RN-41-U	USB firmware (HCI over USB port, slave device at 12Mbps rate)
For other configurations, contact Roving Networks directly.	

Visit <http://www.rovingnetworks.com/buynow.php> for current pricing and a list of distributors carrying our products.

**Copyright © 2009 Roving Networks.** All rights reserved.

The Bluetooth trademark and logo are registered trademarks and are owned by the Bluetooth SIG, Inc. All other trademarks are property of their respective owners.

Roving Networks reserves the right to make corrections, modifications, and other changes to its products, documentation and services at any time. Customers should obtain the latest relevant information before placing orders and should verify that such information is current and complete.

Roving Networks assumes no liability for applications assistance or customer product design. Customers are responsible for their products and applications using Roving Networks components. To minimize the risks associated with customer products and applications, customers should provide adequate design and operating safeguards.

Roving Networks products are not authorized for use in safety-critical applications (such as life support) where a failure of the Roving Networks product would reasonably be expected to cause severe personal injury or death, unless officers of the parties have executed an agreement specifically governing such use.